

Dell EMC PowerEdge R640

Technical Specifications

Notes, cautions, and warnings

 | **NOTE:** A NOTE indicates important information that helps you make better use of your product.

 | **CAUTION:** A CAUTION indicates either potential damage to hardware or loss of data and tells you how to avoid the problem.

 | **WARNING:** A WARNING indicates a potential for property damage, personal injury, or death.

© 2017 - 2018 Dell Inc. or its subsidiaries. All rights reserved. Dell, EMC, and other trademarks are trademarks of Dell Inc. or its subsidiaries. Other trademarks may be trademarks of their respective owners.

Contents

1 Dell EMC PowerEdge R640 system overview.....	4
2 Technical specifications.....	5
System dimensions.....	5
Chassis weight.....	6
Processor specifications.....	6
Cooling fans specifications.....	6
PSU specifications.....	6
System battery specifications.....	7
Expansion bus specifications.....	7
Memory specifications.....	7
Storage controller specifications.....	7
Hard drive specifications.....	8
Drives.....	8
Optical drive.....	8
Ports and connectors specifications.....	8
USB ports.....	8
NIC ports.....	9
Serial port.....	9
VGA ports.....	9
iSDM or vFlash card.....	10
Environmental specifications.....	10
Standard operating temperature.....	12
Expanded operating temperature.....	12
Particulate and gaseous contamination specifications.....	14
3 Documentation resources.....	16
4 Getting help.....	18
Contacting Dell EMC.....	18
Documentation feedback.....	18
Accessing system information by using QRL.....	18
Quick Resource Locator for R640.....	19
Receiving automated support with SupportAssist	19
Recycling or End-of-Life service information.....	19

Dell EMC PowerEdge R640 system overview

The Dell EMC PowerEdge R640 system is a 1U rack server that supports up to:

- Two Intel Xeon Scalable Processors
- 24 DIMM slots
- 8 x 2.5-inch hard drives or 4 x 3.5-inch hard drives on the front panel, or 10 x 2.5-inch hard drives on the front panel with optional support for 2 X 2.5-inch hard drives on the back panel
- Two AC or DC redundant power supply units

NOTE: All instances of SAS, SATA hard drives, SSDs, NVMe drives are referred to as drives in this document, unless specified otherwise.

Technical specifications

System dimensions

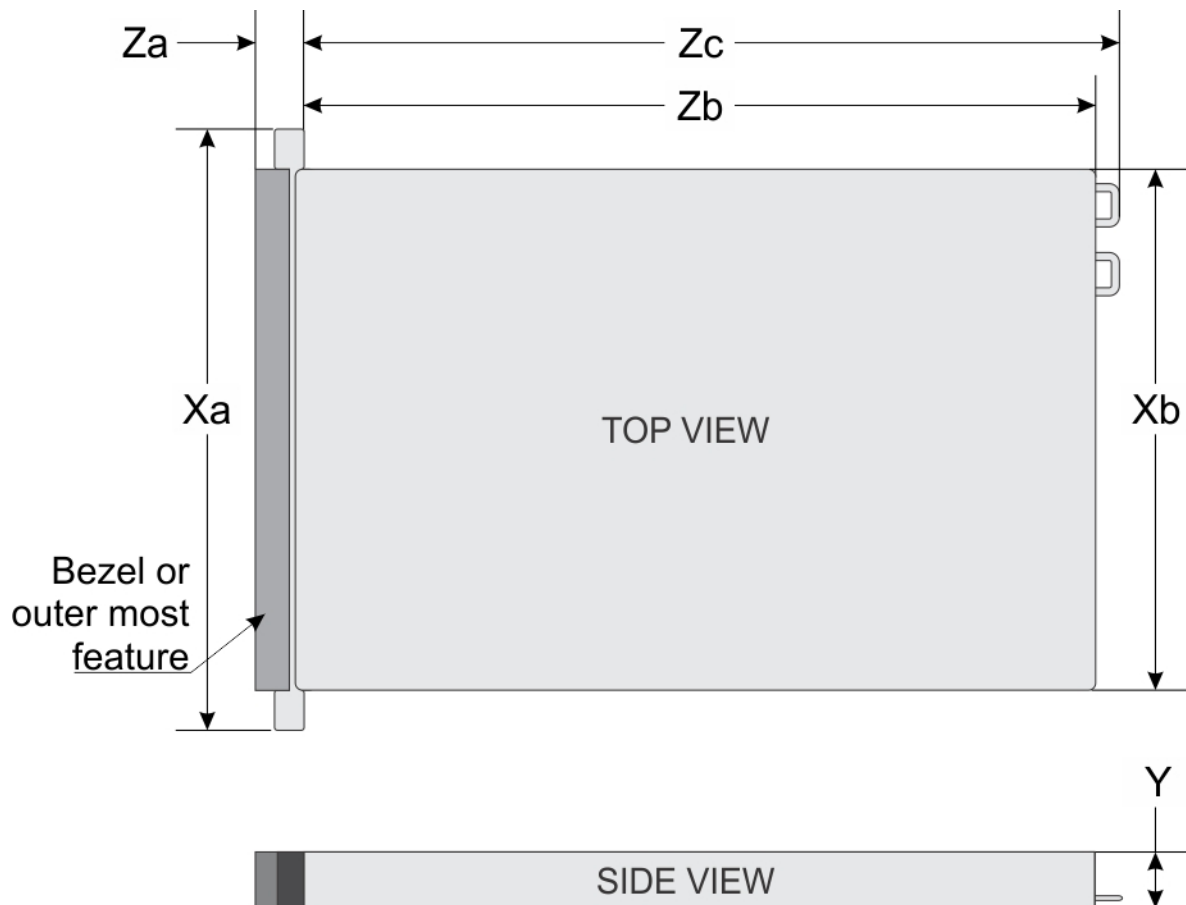

Figure 1. System dimensions

Table 1. Dimensions

System	Xa	Xb	Y	Za (with bezel)	Za (without bezel)	Zb*	Zc
4 x 3.5-inches or 10 x 2.5-inches	482.0 mm (18.97-inches)	434.0 mm (17.08-inches)	42.8 mm (1.68-inches)	35.84 mm (1.41-inches)	22.0 mm (0.87-inches)	733.82 mm (29.61-inches)	772.67 mm (30.42-inches)
8 x 2.5-inches	482.0 mm	434.0 mm (17.08-inches)	42.8 mm (1.68-inches)	35.84 mm (1.41-inches)	22.0 mm (0.87-inches)	683.05 mm (26.89-inches)	721.91

System	Xa	Xb	Y	Za (with bezel)	Za (without bezel)	Zb*	Zc
	(18.97-inches)						(28.42-inches)

Chassis weight

Table 2. Chassis weight

System	Maximum weight (with all hard drives/SSDs)
PowerEdge R640	21.9 kg (48.28 lbs)

Processor specifications

The PowerEdge R640 system supports two Intel Xeon Scalable Processors, up to 28 cores per processor.

Cooling fans specifications

PSU specifications

The PowerEdge R640 system supports up to two AC or DC power supply units (PSUs).

Table 3. PSU specifications

PSU	Class	Heat dissipation (maximum)	Frequency	Voltage
495 W AC	Platinum	1908 BTU/hr	50/60 Hz	100–240 V AC, autoranging
750 W AC	Platinum	2891 BTU/hr	50/60 Hz	100–240 V AC, autoranging
750 W AC	Titanium	2843 BTU/hr	50/60 Hz	200–240 V AC, autoranging
750 W Mixed Mode HVDC (for China only)		2891 BTU/hr	50/60 Hz	100–240 V AC and 240 V DC
1100 W DC	Gold	4416 BTU/hr	50/60 Hz	–(48–60) V DC
1100 W Mixed Mode HVDC (for China and Japan only)	Platinum	4100 BTU/hr	50/60 Hz	100–240 V AC and 200–380 V DC
1100 W AC	Platinum	4100 BTU/hr	50/60 Hz	100–240 V AC, autoranging
1600 W AC		6000 BTU/hr	50/60 Hz	100–240 V AC, autoranging

NOTE: If a system with 1100 W AC or HVDC PSU operates from 100 to 120V, the power rating per PSU is derated to 1050 W.

NOTE: If a system with 1600 W PSUs operates from 100 to 120 V, then the power rating per PSU is derated to 800 W.

NOTE: Heat dissipation is calculated using the PSU wattage rating.

① | **NOTE:** This system is also designed to connect to the IT power systems with a phase to phase voltage not exceeding 230 V.

① | **NOTE:** PSUs rated for 1600 W and higher require high-line voltage (200-240 V) to supply their rated capacity.

System battery specifications

The PowerEdge R640 system supports CR 2032 lithium coin cell system battery.

Expansion bus specifications

The PowerEdge R640 system supports PCI express (PCIe) generation 3 expansion cards, which are installed on the system, using expansion card risers. This system supports 1A, 2A, 1B, and 2B expansion card risers.

Memory specifications

The PowerEdge R640 system supports up to twenty four 288-pins RDIMMS, LRDIMMS and NVDIMM-Ns with speeds of 2666 MT/s, 2400 MT/s and 2133 MT/s with support for memory optimized operation.

Table 4. Memory specifications

DIMM type	DIMM rank	DIMM capacity	Single processor		Dual processors	
			Minimum RAM	Maximum RAM	Minimum RAM	Maximum RAM
LRDIMM	Octa rank	128 GB	128 GB	1536 GB	256 GB	3072 GB
LRDIMM	Quad rank	64 GB	64 GB	768 GB	128 GB	1536 GB
RDIMM	Single rank	8 GB	8 GB	96 GB	16 GB	192 GB
RDIMM	Dual rank	16 GB	16 GB	192 GB	32 GB	384 GB
RDIMM	Dual rank	32 GB	32 GB	384 GB	64 GB	768 GB
NVDIMM-N	Single rank	16 GB	Not supported with single processor	Not supported with single processor	RDIMM: 192 GB	RDIMM: 384 GB
					NVDIMM-N: 16 GB	NVDIMM-N: 192 GB

① | **NOTE:** 8 GB RDIMMs and NVDIMM-N must not be mixed.

① | **NOTE:** Minimum of two CPUs are required for any configurations that support NVDIMM-N.

Storage controller specifications

The PowerEdge R640 system supports:

- **Internal storage controller cards:** PowerEdge RAID Controller (PERC) H330, H730p, H740p, Software RAID (SWRAID) S140.
- **Boot Optimized Storage Subsystem:** HWRAID 2 x M.2 SSDs 120GB, 240 GB.
 - The card supports up to two 6 Gbps M.2 SATA drives. The BOSS adapter card has a x8 connector using PCIe gen 2.0 x2 lanes, available only in the low-profile and half-height form factor.
- **External PERC (RAID):** H840
- **12Gbps SAS HBAs (non-RAID):**
 - External- 12Gbps SAS HBA (non-RAID)
 - Internal- HBA330 (non-RAID)

Hard drive specifications

The PowerEdge R640 supports SAS, SATA, Nearline SAS hard drives or solid state drives and an optional optical drive.

Table 5. Supported drive options for the PowerEdge R640 system

Ten drive systems with two rear drives	Up to ten 2.5 inch, hot swappable SAS, SATA, SAS/SATA SSD, or Nearline SAS hard drives with up to 2 x 2.5 inch hot swappable SAS, SATA, SAS/SATA SSD, or Nearline SAS hard drives supported at the back of the system.
Eight drive systems	Up to eight 2.5 inch, hot swappable SAS, SATA, SAS/SATA SSD, or Nearline SAS hard drives
Four drive systems with two rear drives	Up to four 3.5 inch, hot swappable hard drives with up to 2 x 2.5 inch hot swappable SAS, SATA, SAS/SATA SSD, or Nearline SAS hard drives supported at the back of the system.

Drives

Optical drive

Certain configurations of the system support one optional SATA DVD-ROM drive or DVD+/-RW drive.

NOTE: The optical drive is supported in both 4 x 3.5 and 8 x 2.5 inch hard drive systems.

Ports and connectors specifications

USB ports

The PowerEdge R640 system supports:

The following table provides more information about the USB specifications:

Table 6. USB specifications

System	Front panel	Back panel	Internal
Four hard drive systems	One 4-pin, USB 2.0-compliant ports	Two 9-pin, USB 3.0-compliant ports	N/A
	One 5-pin micro USB 2.0 management port	N/A	N/A

NOTE: The micro USB 2.0-compliant port on the front panel can only be used as an iDRAC Direct or a management port.

System	Front panel	Back panel	Internal
Eight hard drive systems	One 4-pin, USB 2.0-compliant ports	Two 9-pin, USB 3.0-compliant ports	N/A
		 NOTE: One optional USB 3.0-compliant port on the front panel for 4 x 3.5 and 8 x 2.5 inch hard drive systems.	
	One 5-pin micro USB 2.0 management port	N/A	N/A
Ten hard drive systems	One 4-pins, USB 2.0-compliant port	Two 9-pin, USB 3.0-compliant ports	One 9-pin, USB 3.0-compliant ports
	One 5-pin micro USB 2.0 management port	N/A	N/A

NIC ports

The PowerEdge R640 system supports four Network Interface Controller (NIC) ports on the back panel, which are available in the following configurations:

- Four RJ-45 ports that support 10, 100 and 1000 Mbps
- Four RJ-45 ports that support 100 M, 1 G and 10 Gbps
- Four RJ-45 ports, where two ports support maximum of 10 G and the other two ports maximum of 1 Gbps
- Two RJ-45 ports that support up to 1 Gbps and 2 SFP+ ports that support up to 10 Gbps
- Four SFP+ ports that support up to 10 Gbps
- Two SFP28 ports that support up to 25 Gbps

 **NOTE: You can install up to three PCIe add-on NIC cards.**

Serial port

The PowerEdge R640 system supports one serial port on the back panel. This port is a 9-pin connector, Data Terminal Equipment (DTE), 16550-compliant.

VGA ports

The Video Graphic Array (VGA) port enables you to connect the system to a VGA display. The PowerEdge R640 system supports one 15-pin VGA port on the front and back of system.

Video specifications

The PowerEdge R640 system supports integrated Matrox G200eW3 graphics controller with 16 MB of video frame buffer .

Table 7. Supported video resolution options

Resolution	Refresh rate (Hz)	Color depth (bits)
640 x 480	60, 70	8, 16, 32
800 x 600	60, 75, 85	8, 16, 32
1024 x 768	60, 75, 85	8, 16, 32
1152 x 864	60, 75, 85	8, 16, 32
1280 x 1024	60, 75	8, 16, 32
1440 x 900	60	8, 16, 32
1920 x 1200	60	8, 16, 32

IDSDM or vFlash card

The PowerEdge R640 system supports Internal Dual SD module (IDSDM) and vFlash card. In the 14th generation of PowerEdge servers, IDSDM and vFlash card are combined into a single module, and are available in the following options:

- vFlash or
- vFlash and IDSDM

The IDSDM/vFlash card can be connected in a Dell-proprietary PCIe x1 slot using a USB 3.0 interface to host. IDSDM/vFlash module supports two MicroSD cards for IDSDM and one card for vFlash. The MicroSD card capacity for IDSDM are 16, 32, or 64 GB, while for vFlash the MicroSD card capacity is 16 GB. The IDSDM or vFlash module combines the IDSDM or vFlash features into a single module.

NOTE: There are two dip switches on the IDSDM/vFlash card for write-protection.

NOTE: One IDSDM card slot is dedicated for redundancy.

NOTE: It is recommended to use Dell branded MicroSD cards associated with the IDSDM/vFlash configured systems.

Environmental specifications

NOTE: For additional information about environmental certifications, please refer to the Product Environmental Datasheet located with the Manuals & Documents on Dell.com/poweredgemanuals

Table 8. Temperature specifications

Temperature	Specifications
Storage	–40°C to 65°C (–40°F to 149°F)
Continuous operation (for altitude less than 950 m or 3117 ft)	10°C to 30°C (50°F to 86°F) with no direct sunlight on the equipment. <ul style="list-style-type: none"> NOTE: Maximum of 205 W, 28 core processor is supported in systems with eight 2.5 inch processor direct attached PCIe SSD drives, and three PCIe slot chassis. NOTE: Certain configurations may have ambient temperature restrictions. For more information see the Ambient temperature limitations section.
Fresh air	For information about fresh air, see Expanded Operating Temperature section.

Temperature	Specifications
Maximum temperature gradient (operating and storage)	20°C/h (68°F/h)

Table 9. Relative humidity specifications

Relative humidity	Specifications
Storage	5% to 95% RH with 33°C (91°F) maximum dew point. Atmosphere must be non-condensing at all times.
Operating	10% to 80% relative humidity with 29°C (84.2°F) maximum dew point.

Table 10. Maximum vibration specifications

Maximum vibration	Specifications
Operating	0.26 G _{rms} at 5 Hz to 350 Hz (all operation orientations).
Storage	1.88 G _{rms} at 10 Hz to 500 Hz for 15 min (all six sides tested).

Table 11. Maximum shock specifications

Maximum shock	Specifications
Operating	Six consecutively executed shock pulses in the positive and negative x, y, and z axes of 6 G for up to 11 ms.
Storage	Six consecutively executed shock pulses in the positive and negative x, y, and z axes (one pulse on each side of the system) of 71 G for up to 2 ms.

Table 12. Maximum altitude specifications

Maximum altitude	Specifications
Operating	3048 m (10,000 ft)
Storage	12,000 m (39,370 ft)

Table 13. Operating temperature de-rating specifications

Operating temperature de-rating	Specifications
Up to 35°C (95°F)	Maximum temperature is reduced by 1°C/300 m (1°F/547 ft) above 950 m (3,117 ft).
35°C to 40°C (95°F to 104°F)	Maximum temperature is reduced by 1°C/175 m (1°F/319 ft) above 950 m (3,117 ft).
40°C to 45°C (104°F to 113°F)	Maximum temperature is reduced by 1°C/125 m (1°F/228 ft) above 950 m (3,117 ft).

Standard operating temperature

Table 14. Standard operating temperature specifications

Standard operating temperature	Specifications
Continuous operation (for altitude less than 950 m or 3117 ft)	10°C to 35°C (50°F to 95°F) with no direct sunlight on the equipment.

Expanded operating temperature

Table 15. Expanded operating temperature specifications

Expanded operating temperature	Specifications
Continuous operation	<p>5°C–40°C at 5% to 85% RH with 29°C dew point.</p> <p>NOTE: Outside the standard operating temperature (10°C–35°C), the system can operate continuously in temperatures as low as 5°C and as high as 40°C.</p> <p>For temperatures between 35°C–40°C, de-rate maximum allowable temperature by 1°C per 175 m above 950 m (1°F per 319 ft).</p>
≤ 1% of annual operating hours	<p>–5°C–45°C at 5% to 90% RH with 29°C dew point.</p> <p>NOTE: Outside the standard operating temperature (10°C–35°C), the system can operate down to –5°C or up to 45°C for a maximum of 1% of its annual operating hours.</p> <p>For temperatures between 40°C and 45°C, de-rate maximum allowable temperature by 1°C per 125 m above 950 m (1°F per 228 ft).</p>

NOTE: When operating in the expanded temperature range, system performance may be impacted.

NOTE: When operating in the expanded temperature range, ambient temperature warnings may be reported on the LCD panel and in the System Event Log.

Expanded operating temperature restrictions

- Do not perform a cold startup below 5°C.
- The operating temperature specified is for a maximum altitude of 3050 m (10,000 ft).
- 150 W/8 C, 165 W/12 C and higher wattage processor (TDP>165 W) are not supported.
- Redundant power supply unit is required.
- Non-Dell qualified peripheral cards and/or peripheral cards greater than 25 W are not supported.
- PCIe SSD is not supported.
- Rear installed drives are not supported
- Tape backup unit is not supported.

Thermal restrictions

The following table lists the configurations required for efficient cooling.

Table 16. Thermal restrictions configuration

Configuration	Number of processors	Heatsink	Processor/DIMM blank	DIMM blanks	Maximum number of DIMM blanks	Fan
PowerEdge R640 (2.5 inch hard drives x 10)	1	One 1U standard heat sink for CPU ≤ 165 W	Not required	Required for processor 1	11 blanks	Five standard fans
		One 1U 2-pipe heat sink for CPU=200/205 W and 150 W/165 W FO*	Required			Eight high performance fans
	2	Two 1U standard heat sink for CPU ≤ 165 W	Not required			Eight standard fans
		Two 1U 2-pipe heat sink for CPU=200/205 W and 150 W/165 W FO*		Required	22 blanks	Eight high performance fans
PowerEdge R640 (2.5 inch hard drives x 10 with NVMe drives)	2	Two 1U standard heat sink for CPU ≤ 165 W	Not required	Required	22 blanks	Eight high performance fans
		Two 1U 2-pipe heat sink for CPU=200/205 W and 150 W/165 W FO*				
PowerEdge R640 (2.5 inch hard drives x 8) (3.5 inch hard drives x 4)	1	One 1U standard heat sink for CPU ≤ 165 W	No	Required for processor 1	11 blanks	Five standard fans
		One 1U 2-pipe heat sink for CPU=150 W/165 W FO*				
		One 1U 2-pipe heat sink for CPU=200/205 W				
	2	Two 1U standard heat sink for CPU ≤ 165 W				
		Two 1U 2-pipe heat sink for CPU=150 W/165 W	Yes			Eight high performance fans
		Two 1U 2-pipe heat sink for CPU=200/205 W	No	Required	22 blanks	Eight standard fans Eight high performance fans

NOTE: *165 W and 150 W FO includes Intel Xeon Gold 6146 and 6144 processors.

Ambient temperature limitations

The following table lists configurations that require ambient temperature less than 35°C.

NOTE: The ambient temperature limit must be adhered to ensure proper cooling and to avoid excess processor throttling, which may impact system performance.

Table 17. Configuration based ambient temperature restrictions

System	Front Backplane	Processor Thermal Design Power	Processor Heat Sink	Fan Type	Ambient Restriction
PowerEdge R640	10 x 2.5 inch SAS/SATA hard drives	200 W, 205 W	2 pipe 1U high performance	High performance fan	30°C
	8 x 2.5 inch SAS/SATA hard drives				
	4 x 3.5 inch SAS/SATA hard drives				
	10 x 2.5 inch SAS/SATA and NVMe drives(4, 8, or 10)	165 W, 200 W, 205 W	2 pipe 1U high performance	High performance fan	30°C

Particulate and gaseous contamination specifications

The following table defines the limitations that help avoid any equipment damage or failure from particulate and gaseous contamination. If the levels of particulate or gaseous pollution exceed the specified limitations and result in equipment damage or failure, you may need to rectify the environmental conditions. Remediation of environmental conditions is the responsibility of the customer.

Table 18. Particulate contamination specifications

Particulate contamination	Specifications
Air filtration	<p>Data center air filtration as defined by ISO Class 8 per ISO 14644-1 with a 95% upper confidence limit.</p> <p>NOTE: This condition applies to data center environments only. Air filtration requirements do not apply to IT equipment designed to be used outside a data center, in environments such as an office or factory floor.</p> <p>NOTE: Air entering the data center must have the MERV11 or MERV13 filtration.</p>
Conductive dust	<p>Air must be free of conductive dust, zinc whiskers, or other conductive particles.</p> <p>NOTE: This condition applies to data center and non-data center environments.</p>
Corrosive dust	<ul style="list-style-type: none"> Air must be free of corrosive dust. Residual dust present in the air must have a deliquescent point less than 60% relative humidity.

Particulate contamination**Specifications**

NOTE: This condition applies to data center and non-data center environments.

Table 19. Gaseous contamination specifications**Gaseous contamination****Specifications**

Copper coupon corrosion rate

<300 Å/month per Class G1 as defined by ANSI/ISA71.04-1985.

Silver coupon corrosion rate

<200 Å/month as defined by AHSRAE TC9.9.

NOTE: Maximum corrosive contaminant levels measured at ≤50% relative humidity.

Documentation resources

This section provides information about the documentation resources for your system.

To view the document that is listed in the documentation resources table:

- From the Dell EMC support site:
 - a Click the documentation link that is provided in the Location column in the table.
 - b Click the required product or product version.
- **i | NOTE: To locate the product name and model, see the front of your system.**
 - c On the Product Support page, click **Manuals & documents**.
- Using search engines:
 - Type the name and version of the document in the search box.

Table 20. Additional documentation resources for your system

Task	Document	Location
Setting up your system	For more information about installing and securing the system into a rack, see the Rail Installation Guide included with your rack solution. For information about setting up your system, see the <i>Getting Started Guide</i> document that is shipped with your system.	Dell.com/poweredgemanuals
Configuring your system	For information about the iDRAC features, configuring and logging in to iDRAC, and managing your system remotely, see the Integrated Dell Remote Access Controller User's Guide. For information about understanding Remote Access Controller Admin (RACADM) subcommands and supported RACADM interfaces, see the RACADM CLI Guide for iDRAC. For information about Redfish and its protocol, supported schema, and Redfish Eventing implemented in iDRAC, see the Redfish API Guide. For information about iDRAC property database group and object descriptions, see the Attribute Registry Guide.	Dell.com/poweredgemanuals
	For information about earlier versions of the iDRAC documents. To identify the version of iDRAC available on your system, on the iDRAC web interface, click ? > About .	Dell.com/idracmanuals
	For information about installing the operating system, see the operating system documentation.	Dell.com/operatingsystemmanuals

Task	Document	Location
	For information about updating drivers and firmware, see the Methods to download firmware and drivers section in this document.	Dell.com/support/drivers
Managing your system	For information about systems management software offered by Dell, see the Dell OpenManage Systems Management Overview Guide.	Dell.com/poweredgemanuals
	For information about setting up, using, and troubleshooting OpenManage, see the Dell OpenManage Server Administrator User's Guide.	Dell.com/openmanagemanuals > OpenManage Server Administrator
	For information about installing, using, and troubleshooting Dell OpenManage Essentials, see the Dell OpenManage Essentials User's Guide.	Dell.com/openmanagemanuals > OpenManage Essentials
	For information about installing and using Dell SupportAssist, see the Dell EMC SupportAssist Enterprise User's Guide.	Dell.com/serviceabilitytools
	For information about partner programs enterprise systems management, see the OpenManage Connections Enterprise Systems Management documents.	Dell.com/openmanagemanuals
Working with the Dell PowerEdge RAID controllers	For information about understanding the features of the Dell PowerEdge RAID controllers (PERC), Software RAID controllers, or BOSS card and deploying the cards, see the Storage controller documentation.	Dell.com/storagecontrollermanuals
Understanding event and error messages	For information about checking the event and error messages generated by the system firmware and agents that monitor system components, see the Event and Error Message Reference Guide for 14th Generation Dell EMC PowerEdge Servers.	Dell.com/qrl
Troubleshooting your system	For information about identifying and troubleshooting the PowerEdge server issues, see the Server Troubleshooting Guide.	Dell.com/poweredgemanuals

Getting help

Topics:

- [Contacting Dell EMC](#)
- [Documentation feedback](#)
- [Accessing system information by using QRL](#)
- [Receiving automated support with SupportAssist](#)
- [Recycling or End-of-Life service information](#)

Contacting Dell EMC

Dell EMC provides several online and telephone based support and service options. If you do not have an active internet connection, you can find contact information about your purchase invoice, packing slip, bill, or Dell EMC product catalog. Availability varies by country and product, and some services may not be available in your area. To contact Dell EMC for sales, technical assistance, or customer service issues:

- 1 Go to Dell.com/support/home
- 2 Select your country from the drop-down menu on the lower right corner of the page.
- 3 For customized support:
 - a Enter your system Service Tag in the **Enter your Service Tag** field.
 - b Click **Submit**.The support page that lists the various support categories is displayed.
- 4 For general support:
 - a Select your product category.
 - b Select your product segment.
 - c Select your product.The support page that lists the various support categories is displayed.
- 5 For contact details of Dell EMC Global Technical Support:
 - a Click [Global Technical Support](#).
 - b The **Contact Technical Support** page is displayed with details to call, chat, or e-mail the Dell EMC Global Technical Support team.

Documentation feedback

You can rate the documentation or write your feedback on any of our Dell EMC documentation pages and click **Send Feedback** to send your feedback.

Accessing system information by using QRL

Ensure that your smartphone or tablet has the QR code scanner installed.

The QRL includes the following information about your system:

- How-to videos
- Reference materials, including the Owner's Manual, LCD diagnostics, and mechanical overview

- Your system service tag to quickly access your specific hardware configuration and warranty information
 - A direct link to Dell to contact technical assistance and sales teams
- 1 Go to Dell.com/qrl and navigate to your specific product or
 - 2 Use your smartphone or tablet to scan the model-specific Quick Resource (QR) code on your system or in the Quick Resource Locator section.

Quick Resource Locator for R640



Figure 2. Quick Resource Locator for PowerEdge R640

Receiving automated support with SupportAssist

Dell EMC SupportAssist is an optional Dell EMC Services offering that automates technical support for your Dell EMC server, storage, and networking devices. By installing and setting up a SupportAssist application in your IT environment, you can receive the following benefits:

- **Automated issue detection** — SupportAssist monitors your Dell EMC devices and automatically detects hardware issues, both proactively and predictively.
- **Automated case creation** — When an issue is detected, SupportAssist automatically opens a support case with Dell EMC Technical Support.
- **Automated diagnostic collection** — SupportAssist automatically collects system state information from your devices and uploads it securely to Dell EMC. This information is used by Dell EMC Technical Support to troubleshoot the issue.
- **Proactive contact** — A Dell EMC Technical Support agent contacts you about the support case and helps you resolve the issue.

The available benefits vary depending on the Dell EMC Service entitlement purchased for your device. For more information about SupportAssist, go to Dell.com/supportassist

Recycling or End-of-Life service information

Take back and recycling services are offered for this product in certain countries. If you want to dispose of system components, visit Dell.com/recyclingworldwide and select the relevant country.